

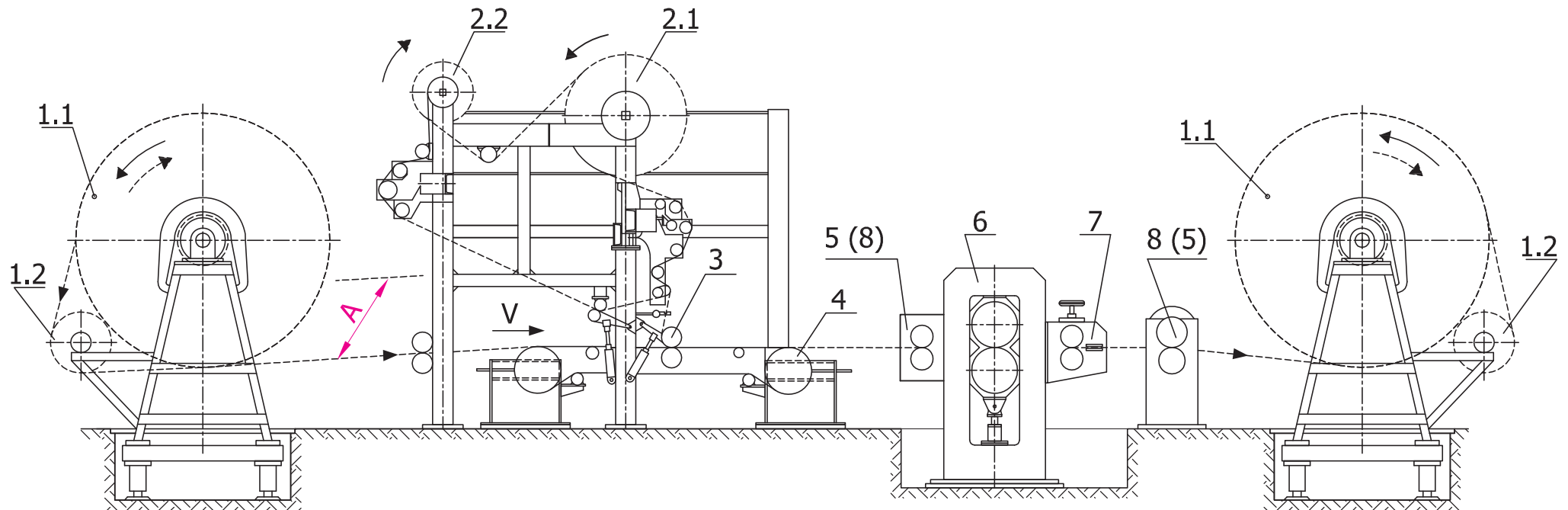

LINE FOR COVERING



Positions:

- 1.1. Winding and unwinding device
- 1.2. Device for winding of linding
- 2.1. Station for unwinding the rubber covering
- 2.2. Station for winding of linding
- 3. The doubling rollers

- 4. Conveyor
- 5. Device for setting of the side covering
- 6. Doubling rollers
- 7. Longitudinal cutting blades
- 8. Hedgehog

Main technical data:

- Purpose: covering of conveyor's belt carcass with rubber
- Standard width (B): 1,6; 2,4; 3,2 [m]
- Working speed: (5÷15) [m/min]
- Other: on your request.

